

Development of
LOCAL WIND PUMP

An Inexpensive Alternative
for
Small Scale Irrigation

The idea:

Inexpensive irrigation
of vegetable farms

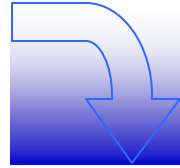

Help to develop vegetable
cultivation as *cash crops*

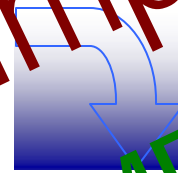

Employment and
income generation



**Poverty Alleviation
in marginal farmers**

No negative impact on
ENVIRONMENT!

1. What is Local Wind Pump?
2. Comparison against conventional wind mills
3. Strategy for development & application of this technology
4. Cost of the project
5. Benefits

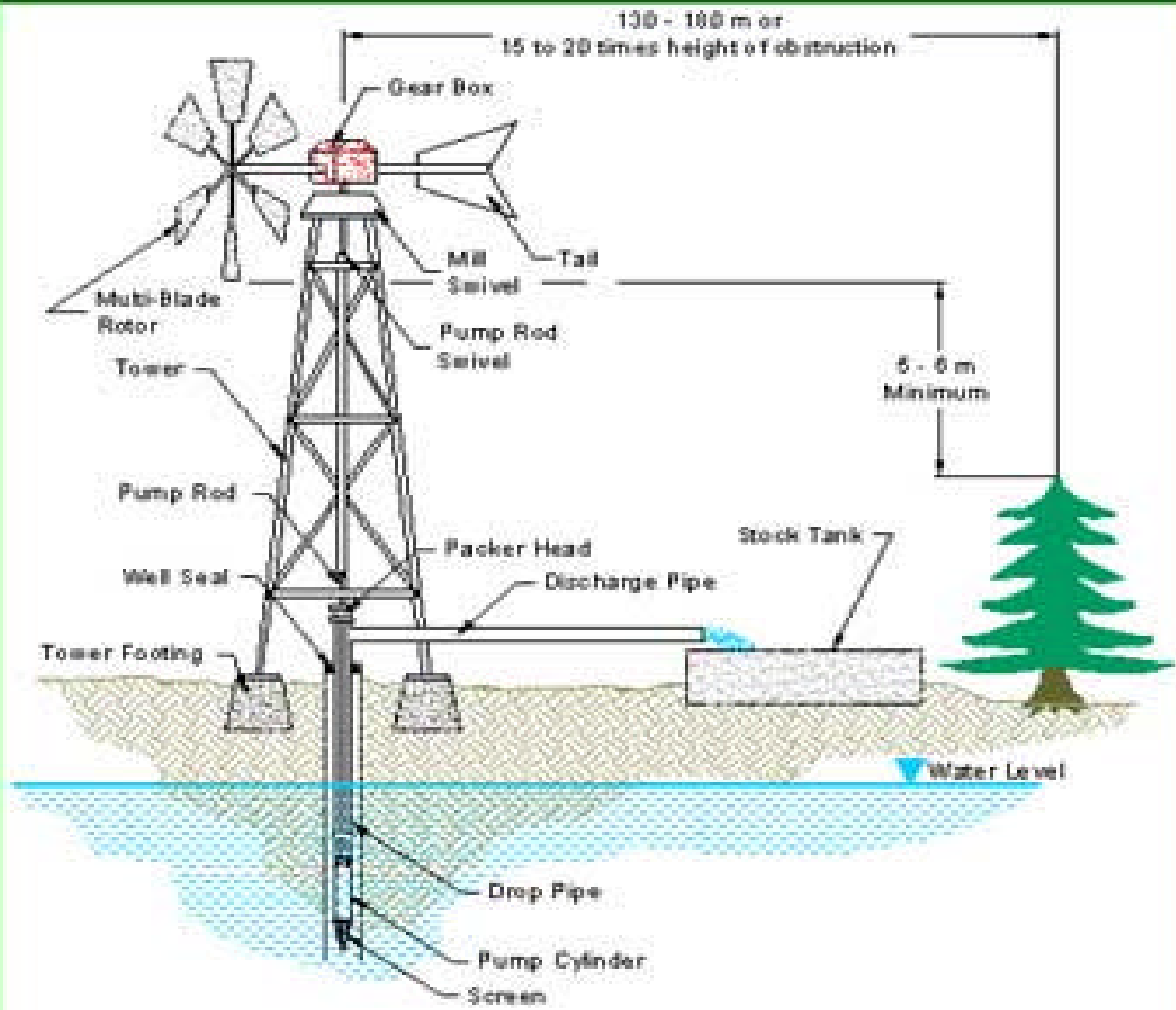

Typical Windmill Water Pump

What is Local Wind Pump?:

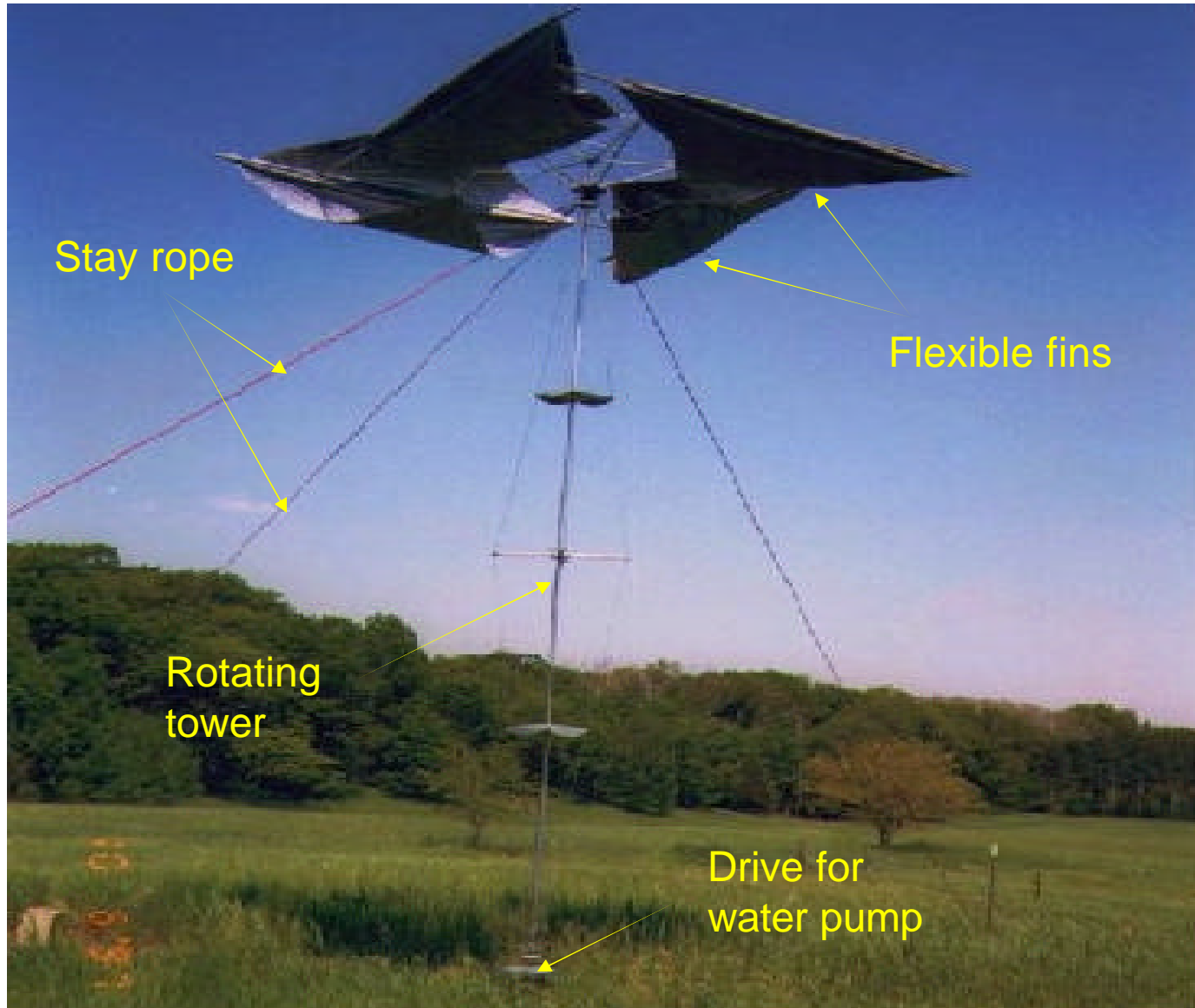

What is Local Wind Pump?:

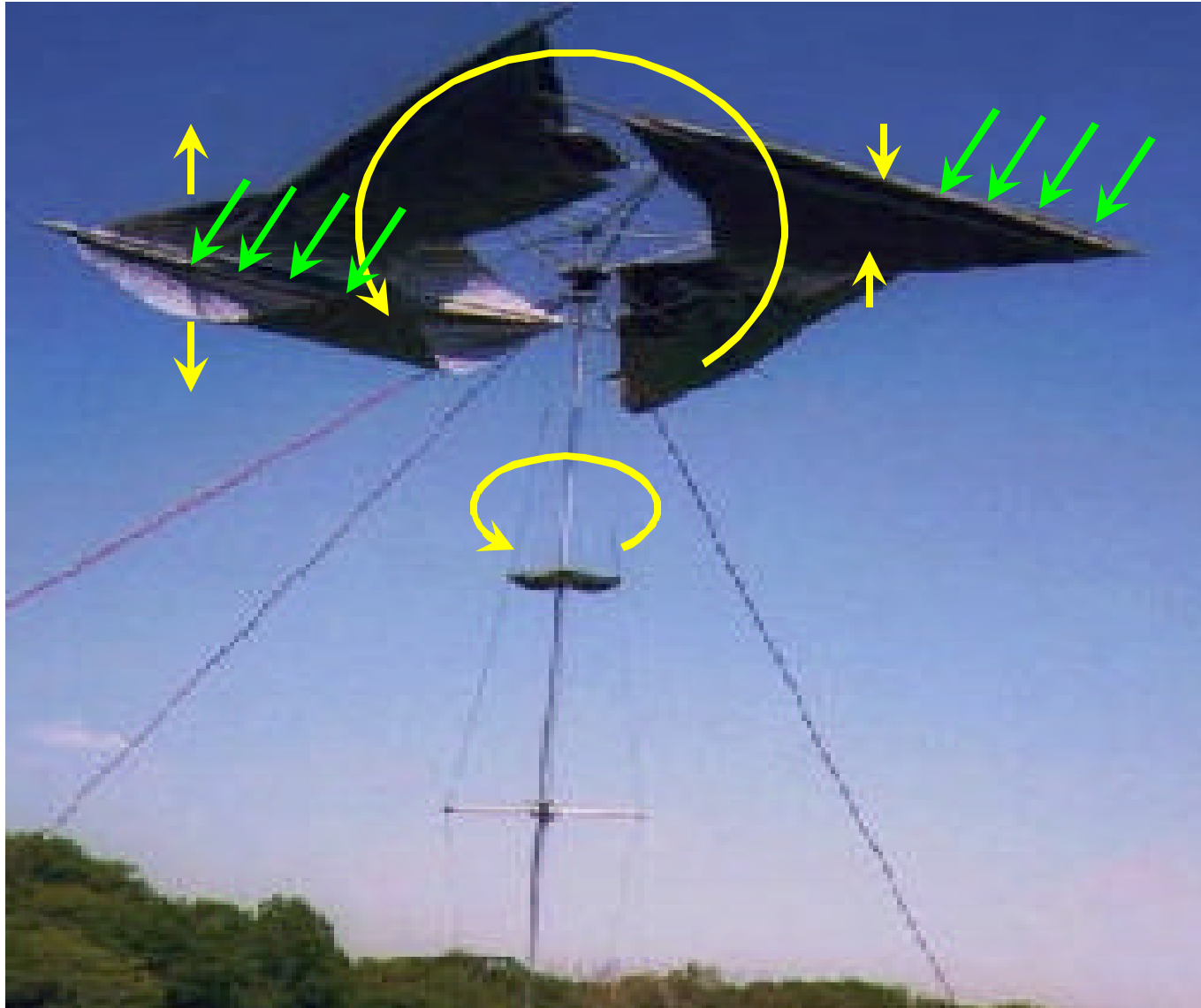

• How Local Wind Pump works?:

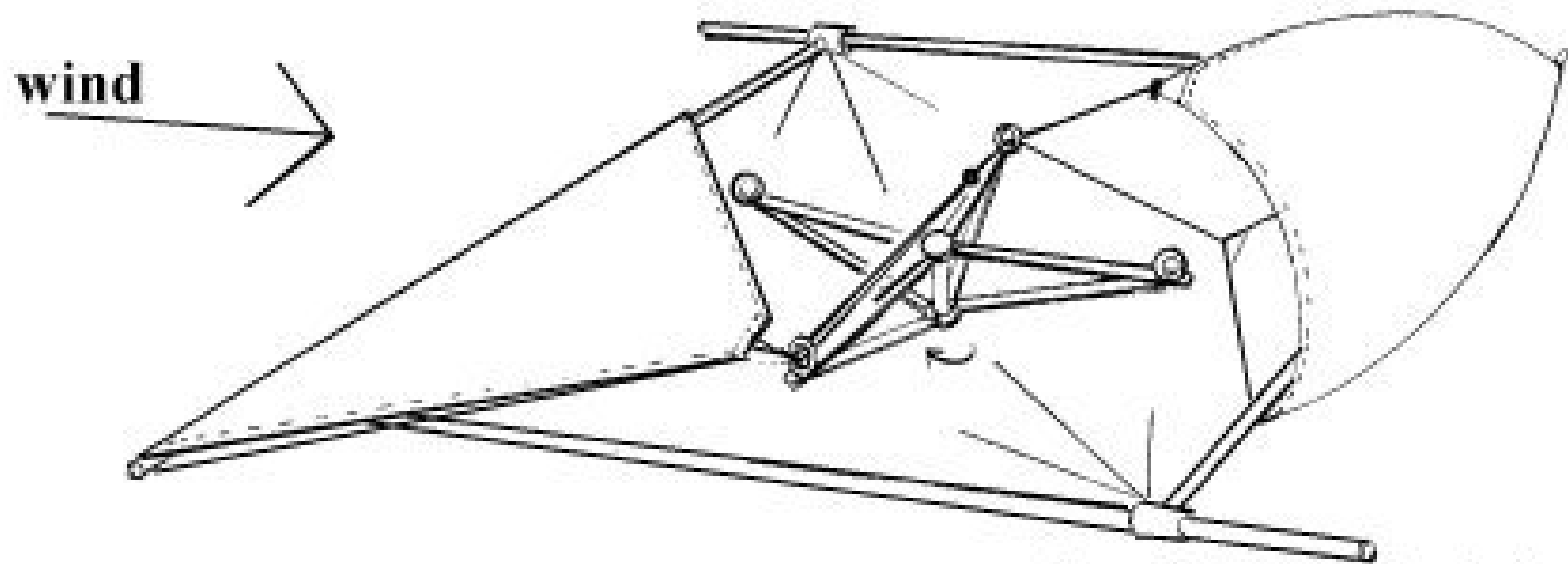

Two sails removed for clarity.

**Linked sails form a scoop when receding from the wind
and a wing when advancing into the wind**

Comparison against conventional wind mills:

Topics		<u>Conventional Windmill</u>	<u>Proposed Local Wind Pump</u>
1	Cost	More expensive than equal capacity micro-hydro generating set (<i>obviously</i>)	Within 40% of the cost of equivalent conventional wind mill.
2	Design development	Requires profound volumes of theories to establish design parameters even after a series of prototype tests because of intricate relationship between nature of winds and aerodynamic profile of blades. Large number of design variables.	Design parameters can be easily established for our purpose to satisfactory level after approx. four number of tests. Less number of design variables.
3	Manufacture and construction	Large number of machinable parts. Special profile of blades. Heavy duty bearings due to high RPM and load. Exposure to environmental attack. Heavy foundation.	Virtually no machinable parts. No special expertise required. A simple wooden pad can serve as foundation and stay wires take care of lateral loads.

Comparison against conventional wind mills:

	<u>Topics</u>	<u>Conventional Windmill</u>	<u>Proposed Local Wind Pump</u>
4	Erection	Requires longer time, special skill and erection devices for handling, leveling and alignment of heavy parts during erection.	Basically there is no erection as such. It can be 'erected' in 25 minutes and dismantled in 15 minutes manually.
5	Operation	Requires regular monitoring by skilled technician.	No special skill required.
6	Effect of fluctuating nature of wind	Sever. Probably one of the reasons of scheme failure. Efficiency drastically falls when wind velocity deviates from design one, since there is no provision for pitch control in small turbines.	Virtually no problem , since - water supply has no stringency of continuous and invariable discharge, - efficiency of the mechanism does not suffer by wind speed variation No control mechanism required.

Comparison against conventional wind mills:

	<u>Topics</u>	<u>Conventional Windmill</u>	<u>Proposed Local Wind Pump</u>
7	Effect of changing direction of wind	In horizontal shaft turbines, to cope with the change in direction of wind, use of tail-vane along with horizontal thrust bearing makes the structure complex , expensive and more sensitive to shock loads.	It is omni-directional . No sensitive part introduced in design.
8	Weight	Besides the rotor, relatively heavy support structure, tail-vane and transmission with more components sum up to give an inconvenient weight to handle.	Extremely less weight of equivalent conventional windmill in total, with no part exceeding the possibility to be handled manually.

Comparison against conventional wind mills:

	<u>Topics</u>	<u>Conventional Windmill</u>	<u>Proposed Local Wind Pump</u>
9	Safety	Most of the past wind power schemes in Nepal were the victims of high wind speed. They were structurally unsafe against wind speed approximately above 80 km/h	It can work satisfactorily in a wide range of wind velocity 3 km/h to 60 km/h. There is no considerable ill effect even over this range. Moreover it can be easily dismantled when wind condition is likely to worsen.
10	Repair & Maintenance	Requires special skill.	No special skill required. Most parts are welded structure.
11	Portability & Suitability	Not portable. Suitability is limited to sites with easy access.	Portable. Possible to install almost anywhere so long as wind is available there.

Strategy for development & application of this technology:

1. Design and development works
2. Manufacture 6 test models
3. Conduct 6 model tests
4. Analysis of test results and final design
5. Safety precautions
6. Site selection and design of prototype
7. Commercial production

Estimated parameters of commercial unit:

Operate in wind velocity	1.5 to 16 m/s
Pump discharge	60 l/min for 20ft lift
Rotor size (diameter)	6.5 m
Starting wind speed	2 m/s
Wt. of complete set excluding. pump	32.0 kg
Assemble / dismantle time	25min / 15 min
Approx. Cost of one commercial unit	34600 Rs.

Further research has been recommended

• Tested Model Results

Test site:

Bajaraguthi,
Saptari

- Wind mill height - 6 meters
- Rotor diameter - 6.5 meters
- Material used - G.I. Pipe, sheath, ropes, Bearings
- Discharge - 18-56 liter/min (lift 20 feet)

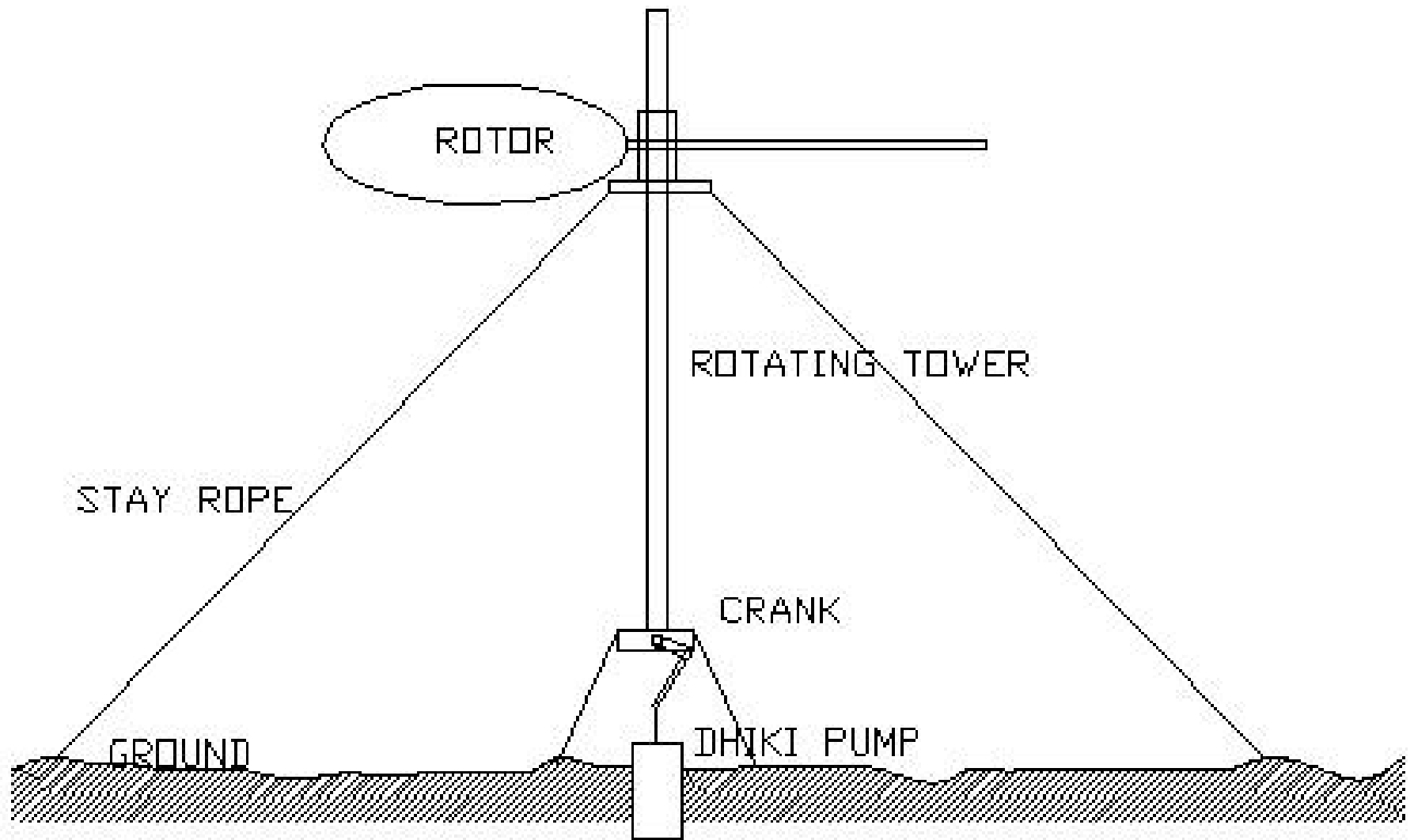

SCHEMATIC DIAGRAM OF TESTED WIND PUMP

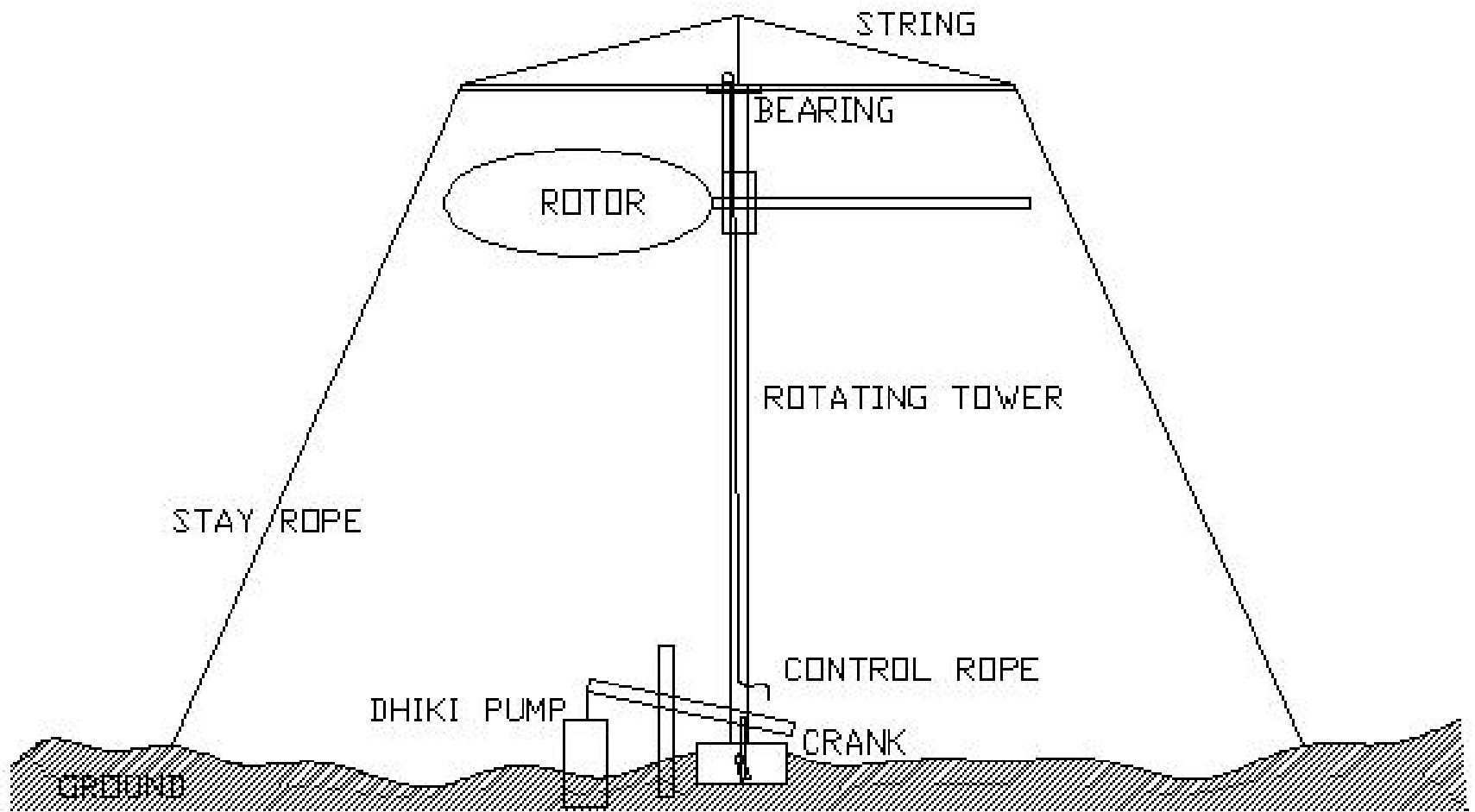

SCHEMATIC DIAGRAM OF PROPOSED WIND PUMP FOR FURTHER RESEARCH

